

Thermal Transfer Printer

USER'S MANUAL

Please keep user manual for reference

LIST

1. Introduction	4
1.1 Product Introduction	4
1.2 Product features	5
1.2.1 Shop accessories	6
1.3 General specifications	6
1.4 Print Specifications	6
1.5 Ribbon Specifications	7
1.6 Media Specifications	7
2. Operations Overview	8
2.1 Unpacking and Inspection	8
2.2 Printer Overview	9
3. Setup	12
3.1 Setting up the Printer	12
3.2 Loading the Ribbon	13
3.3 Loading the Media	17
4. LED and Button Functions	25
4.1 LED Indicator	25
4.2 Regular Button Functions	25
4.3 Power-on Utilities	25
5. Diagnostic Tool	32
5.1 Start the Diagnostic Tool	32
5.2 Printer Function	33
5.3 Calibrating Media Sensor by Diagnostic Tool	34
5.4 Setting Ethernet by Diagnostic Utility (Option)	35
6. Troubleshooting	39
6.1 Common Problems	39
7. Maintenance	42

Copyright Information

The copyright in this manual, the software and firmware in the printer described there in are owned by Shenzhen Chainway Information Technology Co., Ltd. All rights reserved. Information in this document is subject to change without notice and does not represent a commitment on the part of Shenzhen Chainway Information Technology Co., Ltd. No part of this manual may be reproduced or transmitted in any form or by any means, for any purpose other than the purchaser's personal use, without the expressed written permission of Shenzhen Chainway Information Technology Co., Ltd.

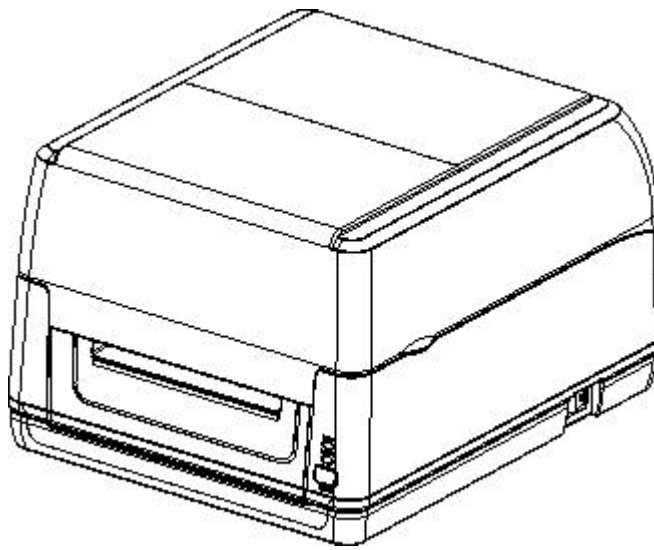

1. Introduction

1.1 Product Introduction

Thank you very much for purchasing heat transfer/thermal barcode printer.

The series printer features single gear-driven motors that are capable of handling large capacity 300 meter ribbons and large rolls of media inside its sleek design. If the 5” interior label capacity is not enough, simply add an external media roll mount and they can easily handle 8.4” OD rolls of labels designed for expensive industrial label printers.

The moveable sensor design can accept wide range of label media. All of the most frequently used barcode formats are included. Fonts and barcodes can be printed in any one of the four directions.

The simulation models are built in font of high quality and efficient (True Type font) and font engine.

With flexible firmware design, user can also download the True Type Font from PC into printer memory for printing labels. Besides the scalable font, it also provides a choice of five different sizes of alphanumeric bitmap font, OCR-A and OCR-B fonts. By integrating rich features, it is the most cost-effective and high performance printer in its class!

To print label formats, please refer to the instructions provided with your labeling software; if you need to write the custom programs, please refer to the CP20 programming manual that can be found on the accessories CD-ROM or on website at <https://www.chainway.cn/>.

Applications

- o Manufacturing & Warehousing
 - Work in Progress
 - Item Labels
 - Instruction labels
 - Agency labels
- o Healthcare
 - Patient Identification
 - Pharmacy
 - Specimen Identification
- o Parcel Post
 - Shipping/ Receiving
- o Small Office/ Home Office
- o Retail Marking
 - Price tags
 - Shelf labels
 - Jewelry

1.2 Product features

1.2.1 Standard accessories

Product standard feature	203 dpi models	300 dpi models								
Thermal transfer printing	<input type="radio"/>	<input type="radio"/>								
Direct thermal printing	<input type="radio"/>	<input type="radio"/>								
ABS plastic enclosure	<input type="radio"/>	<input type="radio"/>								
Position adjustable gap sensor	<input type="radio"/>	<input type="radio"/>								
Position adjustable black mark sensor	<input type="radio"/>	<input type="radio"/>								
Ribbon sensor	<input type="radio"/>	<input type="radio"/>								
Head open sensor	<input type="radio"/>	<input type="radio"/>								
USB 2.0 (full speed) interface	<input type="radio"/>	<input type="radio"/>								
8 MB SDRAM memory	<input type="radio"/>	<input type="radio"/>								
8 MB FLASH memory	<input type="radio"/>	<input type="radio"/>								
MicroSD memory card reader for memory expansion up to 4GB	<input type="radio"/>	<input type="radio"/>								
Real time clock	<input type="radio"/>	<input type="radio"/>								
One power switch, one feed button and LED	<input type="radio"/>	<input type="radio"/>								
Standard industry emulations right out of the box including	<input type="radio"/>	<input type="radio"/>								
Eltron® and Zebra® language support	<input type="radio"/>	<input type="radio"/>								
Internal 8 alpha-numeric bitmap fonts	<input type="radio"/>	<input type="radio"/>								
Fonts and barcodes can be printed in any one of the four directions (0, 90,180, 270 degree)	<input type="radio"/>	<input type="radio"/>								
Embedded font	<input type="radio"/>	<input type="radio"/>								
Downloadable fonts from PC to printer memory	<input type="radio"/>	<input type="radio"/>								
Downloadable firmware upgrades	<input type="radio"/>	<input type="radio"/>								
Text, barcode, graphics/image printing (Please refer to the chainway programming manual for supporting code page)	<input type="radio"/>	<input type="radio"/>								
<table border="1"> <thead> <tr> <th colspan="2">Supported bar code</th> <th>Supported image</th> </tr> </thead> <tbody> <tr> <td>1D bar code</td> <td>2D bar code</td> <td rowspan="2">BITMAP, BMP, PCX (Max. 256 colors graphics)</td> </tr> <tr> <td>Code 39,Code 93, Code128UCC, Code128 subsets A,B,C, Codabar, Interleaved 2 of 5,EAN-8, EAN-13,EAN-128,UPC-A, UPC-E,EAN and UPC 2(5)digits add-on, MSI,PLESSEY, POSTNET,China POST,GS1 DataBar,Code 11</td> <td>PDF-417, Maxicode, DataMatrix, QR code, Aztec, GS1 DataBar Composite code</td> </tr> </tbody> </table>	Supported bar code		Supported image	1D bar code	2D bar code	BITMAP, BMP, PCX (Max. 256 colors graphics)	Code 39,Code 93, Code128UCC, Code128 subsets A,B,C, Codabar, Interleaved 2 of 5,EAN-8, EAN-13,EAN-128,UPC-A, UPC-E,EAN and UPC 2(5)digits add-on, MSI,PLESSEY, POSTNET,China POST,GS1 DataBar,Code 11	PDF-417, Maxicode, DataMatrix, QR code, Aztec, GS1 DataBar Composite code	<input type="radio"/>	<input type="radio"/>
Supported bar code		Supported image								
1D bar code	2D bar code	BITMAP, BMP, PCX (Max. 256 colors graphics)								
Code 39,Code 93, Code128UCC, Code128 subsets A,B,C, Codabar, Interleaved 2 of 5,EAN-8, EAN-13,EAN-128,UPC-A, UPC-E,EAN and UPC 2(5)digits add-on, MSI,PLESSEY, POSTNET,China POST,GS1 DataBar,Code 11	PDF-417, Maxicode, DataMatrix, QR code, Aztec, GS1 DataBar Composite code									

1.2.2 Shop accessories

Product option feature	User options	Dealer options	Factory options
Internal Ethernet print server (10/100 Mbps) interface	-	-	○
Serial RS-232C (2400-115200 bps) interface	-	-	○
Centronics interface	-	-	○
Bluetooth module	-	-	○
Peel-off module	○	-	-
Guillotine cutter module (Full cut and partial cut) Paper thickness: 0.06~ 0.19mm, 500,000 cuts 0.20~ 0.25mm, 200,000 cuts Note: Except for the linerless cutter, all regular/heavy duty/care label cutters DO NOT cut on media with glue.	○	-	-
External roll mount with 3" core (8.4 OD) label spindle	○		
Extended plate for external roll mount	○		
Bluetooth module (RS-232C interface)	○	-	○

1.3 General specifications

General Specifications	
Physical dimensions	282 mm (D) x 232 mm (W) x 171 mm (H)
Weight	2.47 kg
Electrical	External universal switching power supply Input: AC 100-240V Output: DC 24V 2.5A, 60W
Environmental condition	Operation: 5 ~ 40°C (41 ~ 104°F), 25~85% non-condensing Storage: -40 ~ 60 °C (-40 ~ 140° F), 10~90% non-condensing

1.4 Print Specifications

Print Specifications	203 dpi models	300 dpi models
Print head resolution	203 dots/inch (8 dots/mm)	300 dots/inch (12 dots/mm)
Printing method	Thermal transfer and direct thermal	
Dot size (width x length)	0.125 x 0.125 mm(1 mm = 8 dots)	0.084 x 0.084 mm(1 mm = 11.8 dots)
Print speed (inches per second)	2, 3, 4, 5, 6 ips (1ips = 25.4mm/s)	2, 3, 4, 5 ips(1ips = 25.4mm/s)
Print speed for peel mode & cutter mode	2, 3 ips (1ips = 25.4mm/s)	
Max. print width	104 mm (4.09")	104 mm (4.09")
Max. print length	1778 mm (70")	889 mm (35")

1.5 Ribbon Specifications

Ribbon Specifications	
Ribbon outside diameter	Max. 67 mm
Ribbon length	300 meter
Ribbon core inside diameter	1 inch (25.4 mm)
Ribbon width	Max. 110 mm &Min. 40 mm
Ribbon wound type	Outside wound

1.6 Media Specifications

Media Specifications	203 dpi models	300 dpi models
Label roll capacity	127 mm (5") OD	
Media type	Continuous, die-cut, black mark, fan-fold, notch	
Media wound type	Printing face outside wound & Printing face inside wound	
Media width (label +liner)	Max. 118 mm (4.6") Min. 25.4 mm (1.0")	
Media thickness (label+liner)	Max. 0.254 mm (10 mil) Min. 0.06 mm (2.36 mil)	
Media core diameter	25.4 mm~38 mm (1"~1.5")	
Label length	10~1778mm (0.39"~70")	10~889 mm (0.39"~35")
	Note: If your label length is less than 25.4mm (1"), we recommend you to use the perforation at the gap for easier tear away.	
Label length (peeler mode)	Max. 152.4 mm (6") Min. 25.4 mm (1")	
Label length (cutter mode)	Max. 1778 mm (70") Min. 25.4 mm (1")	Max. 889 mm (40") Min. 25.4 mm (1")
Gap height	Min. 2 mm (0.09")	
Black mark height	Min. 2 mm (0.09")	
Black mark width	Min. 8 mm (0.31")	

2. Operations Overview

2.1 Unpacking and Inspection

This printer has been specially packaged to withstand damage during shipping. Please carefully inspect the packaging and printer upon receiving the barcode printer. Please retain the packaging materials in case you need to reship the printer.

Unpacking the printer, the following items are included in the carton.

- One printer unit
- One Windows labeling software/Windows driver CD disk
- One quick installation guide
- One power cord
- One auto switching power supply
- One USB interface cable
- Two ribbon spindle
- One ribbon paper core
- One label spindle

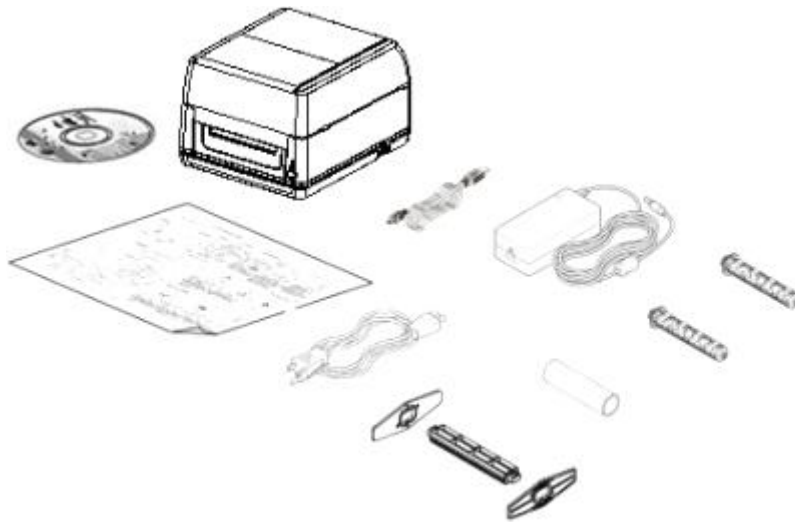

If any parts are missing, please contact the Customer Service Department of your purchased reseller or distributor.

2.2 Printer Overview

2.2.1 Front View

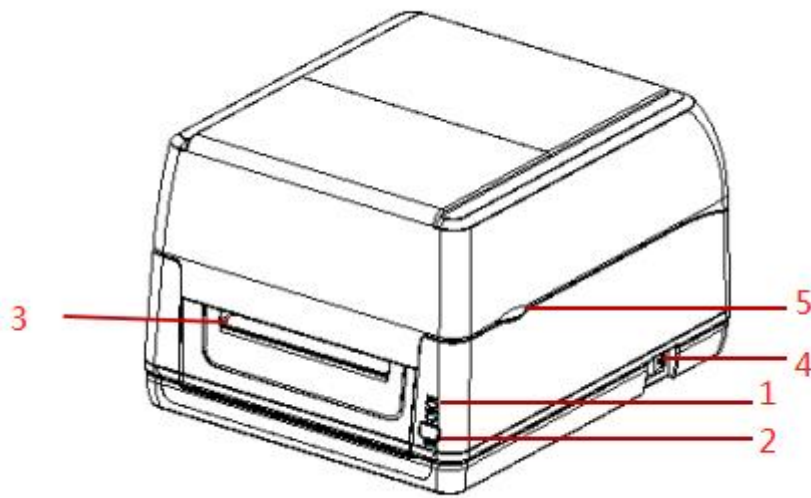

NO.	Name
1	LED indicator
2	Feed key
3	Paper exit chute
4	Power switch
5	Top cover open tab

2.2.2 Interior View

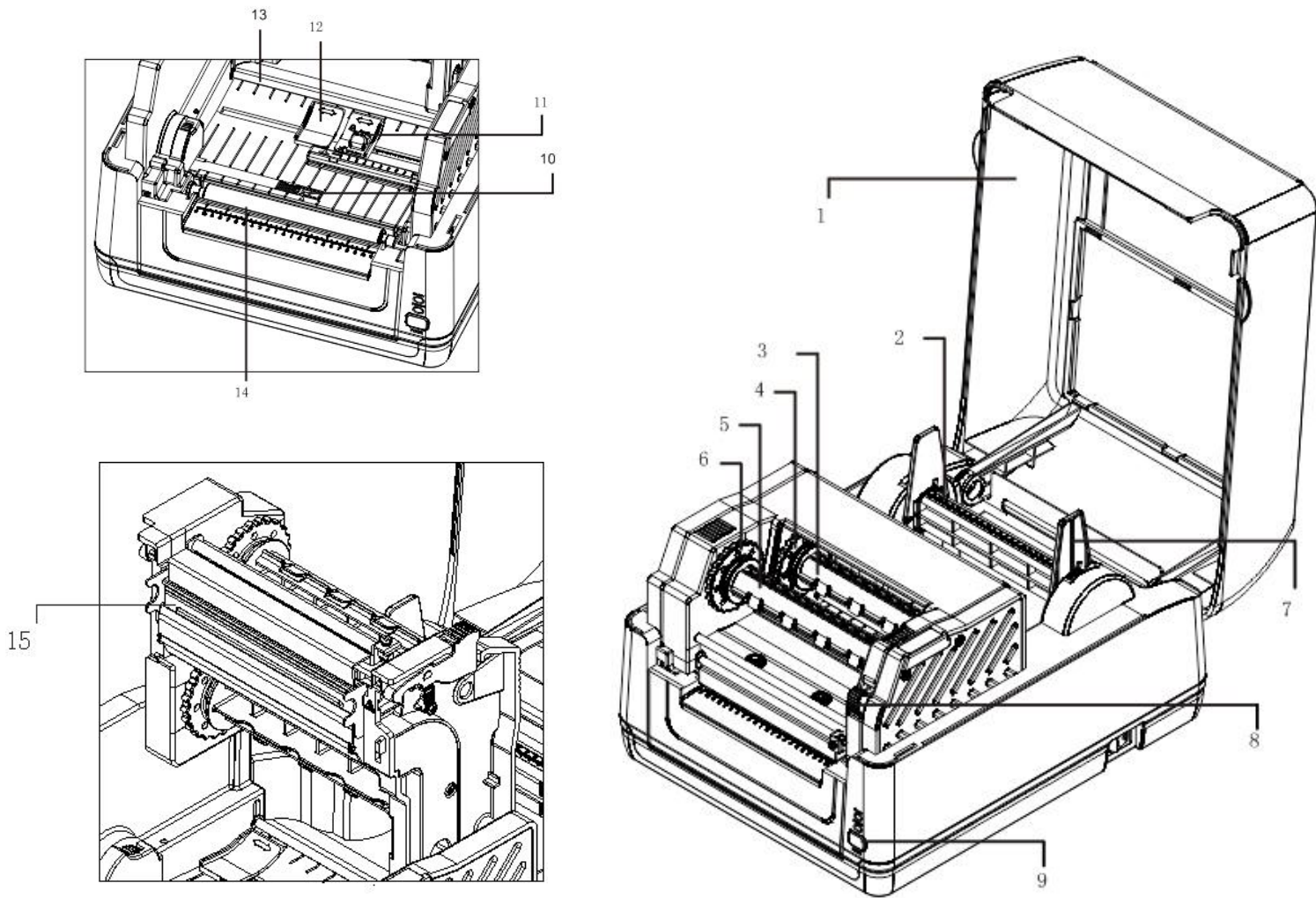

NO.	Name
1	Upper cover of printer
2	Paper roll holder
3	Carbon belt supply shaft
4	Carbon belt supply roller
5	Carbon belt recycling shaft
6	Carbon belt recovery roller
7	Paper roll fixing piece
8	Print head cover opening key
9	Paper feed button
10	Black label sensor
11	Paper clip limit switch
12	Paper clip stopper
13	paper guide shaft
14	Rubber roller
15	Print head

2.2.3 Rear View

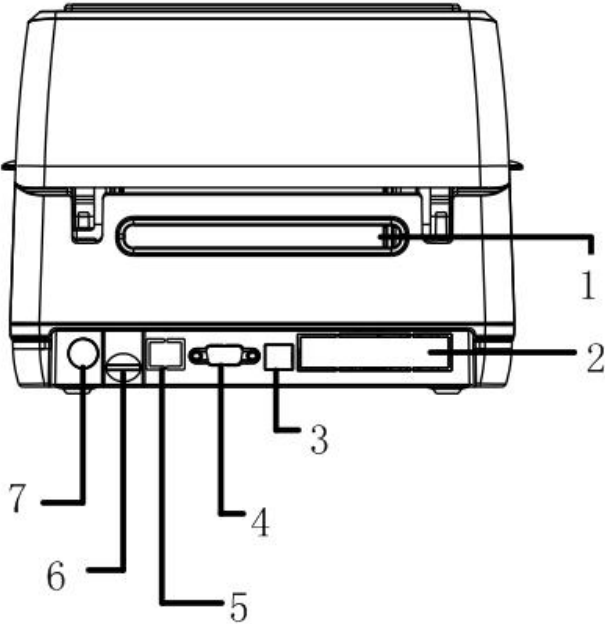

NO.	Name
1	External paper inlet
2	Parallel port (optional)
3	USB interface
4	RS-232C serial port (optional)
5	Network port (optional)
6	MicroSD card slot
7	Power supply connector

Note:
The interface picture here is for reference only. Please refer to the product specification for the interfaces availability.

3. Setup

3.1 Setting up the Printer

1. Place the printer on a flat, secure surface.
2. Make sure the power switch is off.
3. Connect the printer to the computer with the provided USB cable.
4. Plug the power cord into the AC power cord socket at the rear of the printer, and then plug the power cord into a properly grounded power outlet.

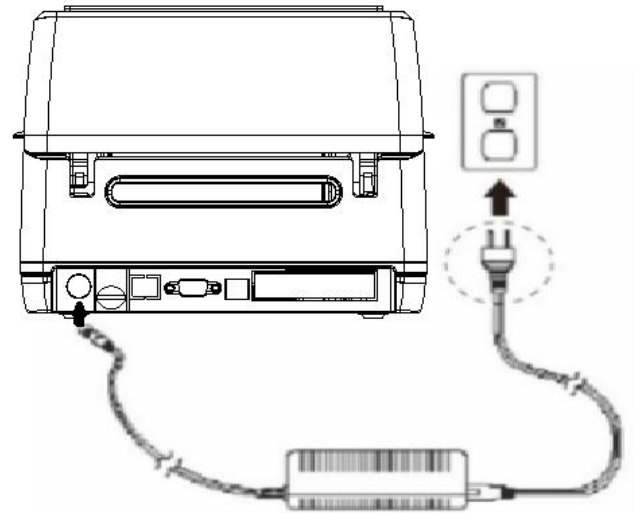

Note:

- * Please switch OFF printer power switch prior to plug in the power cord to printer power jack.
- * The interface picture here is for reference only. Please refer to the product specification for the interfaces availability.

3.2 Loading the Ribbon

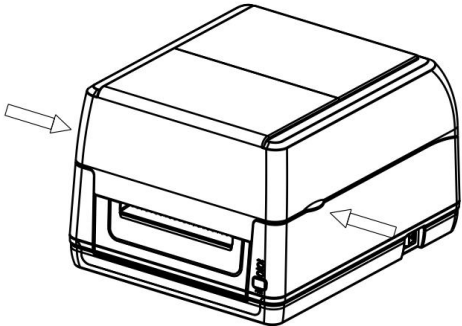
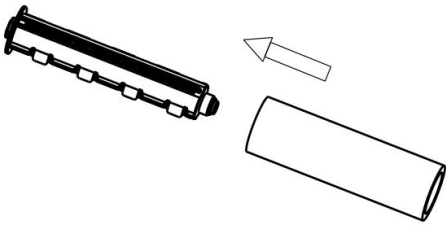
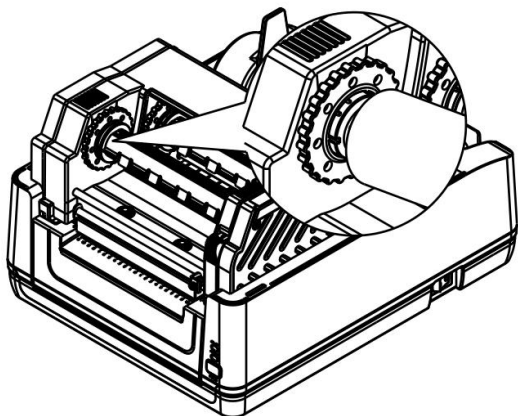
	<p>1. Press the switches on the left and right sides of the upper cover with both hands to open the upper cover of the printer;</p>
	<p>2. Put the empty paper roll into the carbon belt recycling shaft;</p>
	<p>3. Press the left side (hexagonal end) of the recycling shaft into the carbon belt recycling runner (green), and then install the right side;</p>

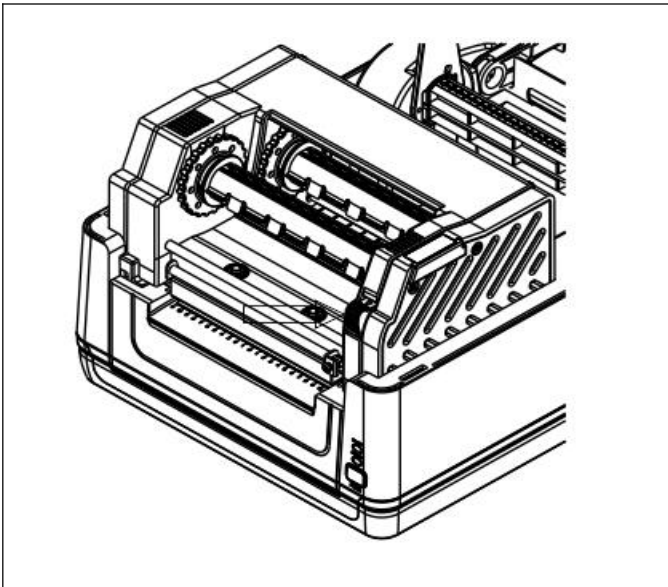

4. Press the print head on switch to turn on the print head;

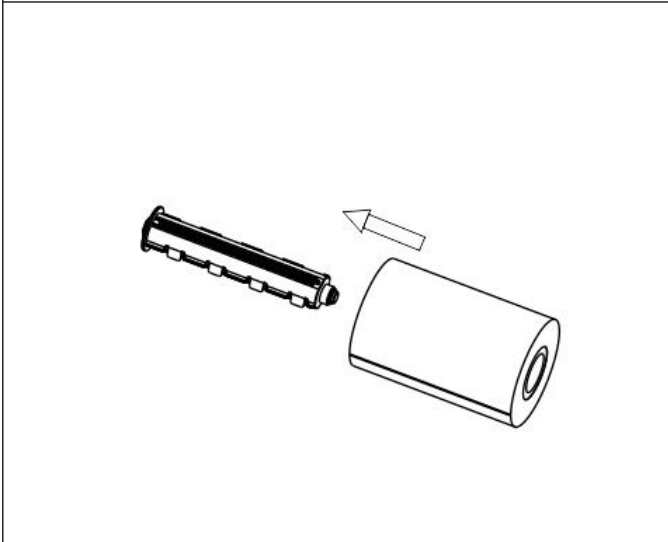

5. Insert the carbon belt into the carbon belt supply shaft;

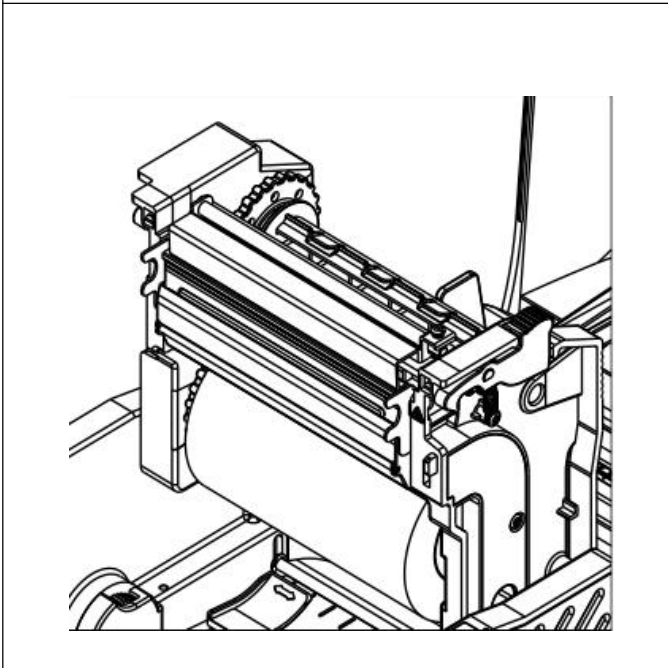

6. Press the left side (hexagonal end) of the supply shaft into the carbon belt supply runner (green), and then install the right side;

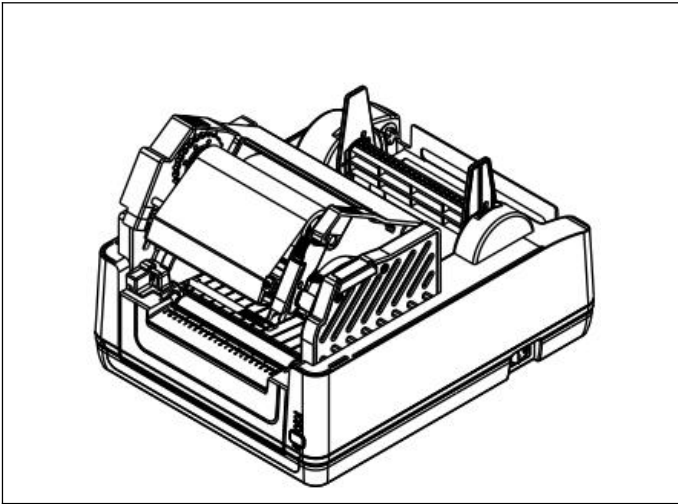

7、 Wrap the carbon tape around the print head and stick it on the carbon tape recycling shaft (empty paper roll) smoothly;

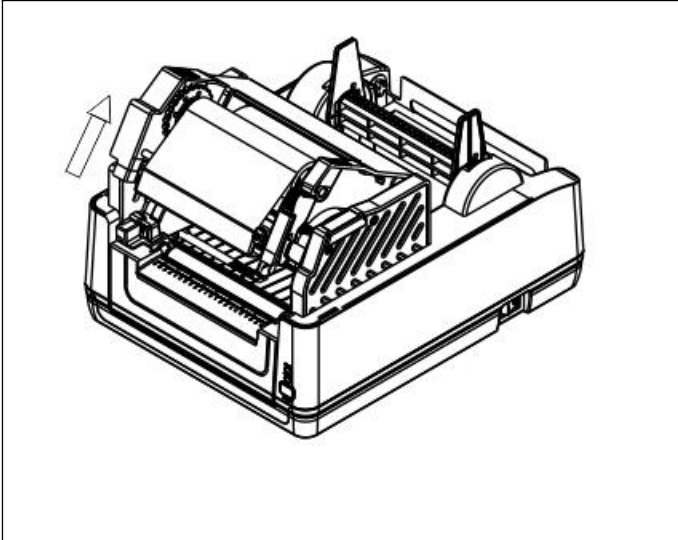

8、 Rotate the carbon belt recycling wheel in the direction of the photo arrow until the black area of the carbon belt covers the print head, and roll the carbon belt tightly so that there are no wrinkles on the carbon belt;

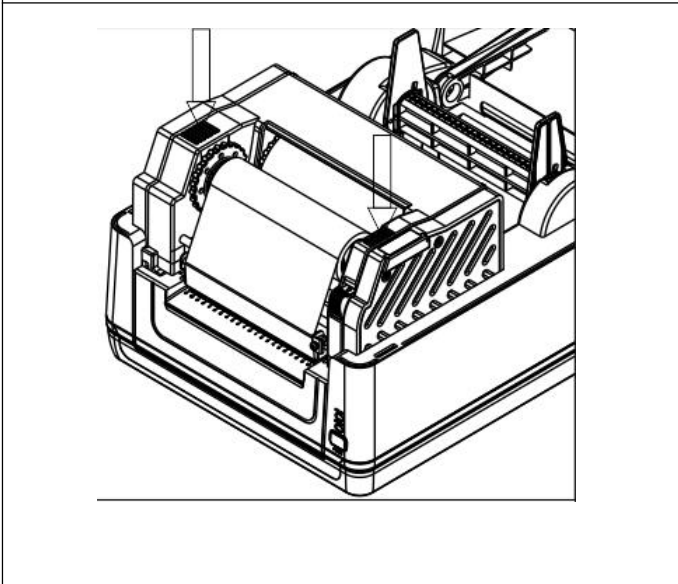

9.As shown in the left figure, press both hands down at the arrow to close the print head. Please make sure that the print head is completely closed to ensure the print quality;

Ribbon loading path

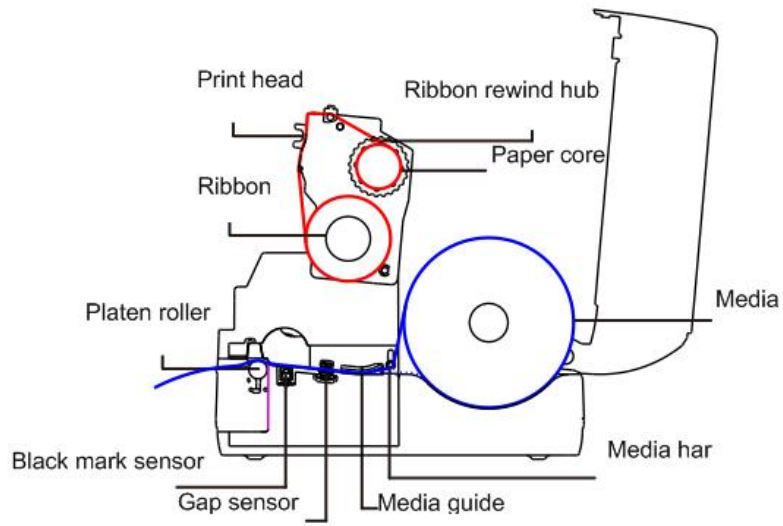

3.3 Loading the Media

3.3.1 Loading the Roll Labels

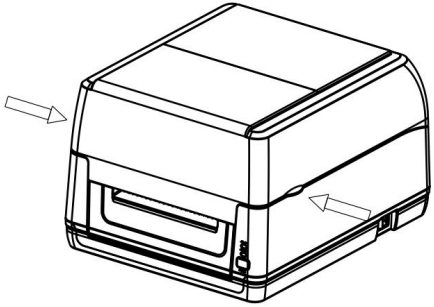
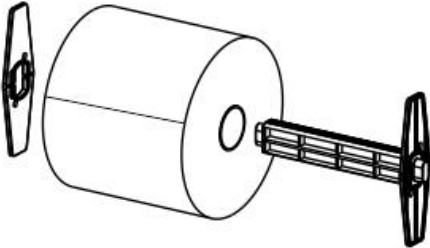
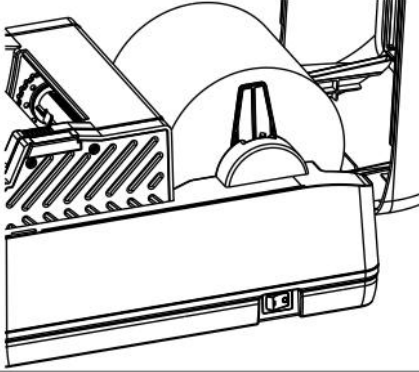
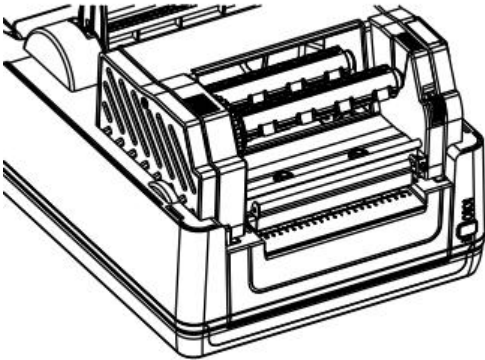
	<p>1、 Press the switches on the left and right sides of the upper cover with both hands to turn on the upper cover of the printer</p>
	<p>2、 Load the roll of paper into the label supply shaft, and fix the roll of paper in the center of the supply shaft with the roll fixing sheet (if you use a 4 "wide roll of paper, you can remove the fixing sheet and directly use the roll of paper).</p>
	<p>3、 Place the paper roll on the paper roll rack;</p>
	<p>4、 Press the print head on switch to turn on the print head;</p>

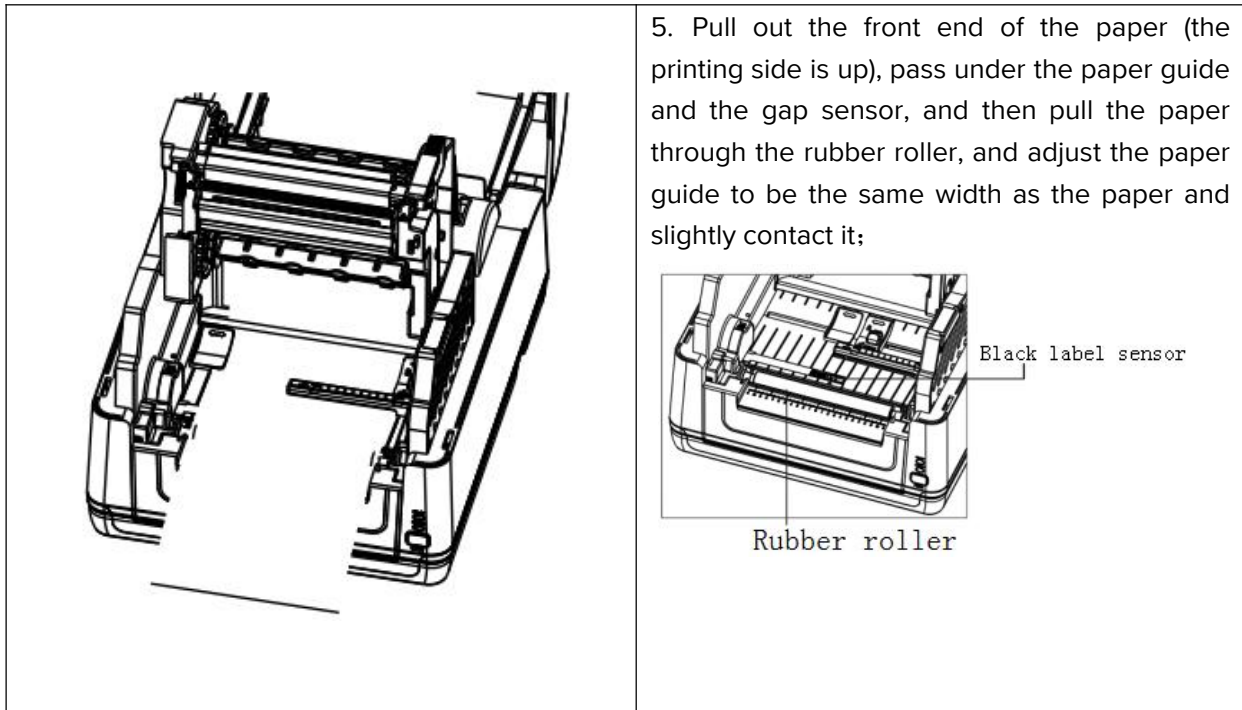

5. Pull out the front end of the paper (the printing side is up), pass under the paper guide and the gap sensor, and then pull the paper through the rubber roller, and adjust the paper guide to be the same width as the paper and slightly contact it;

Note: The label sensor of this series of models is movable. Please make sure that the gap (or black label) of the paper passes through the sensor

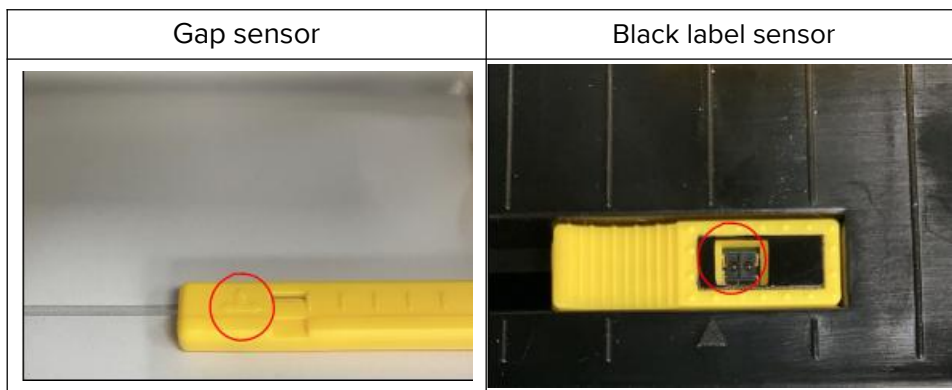

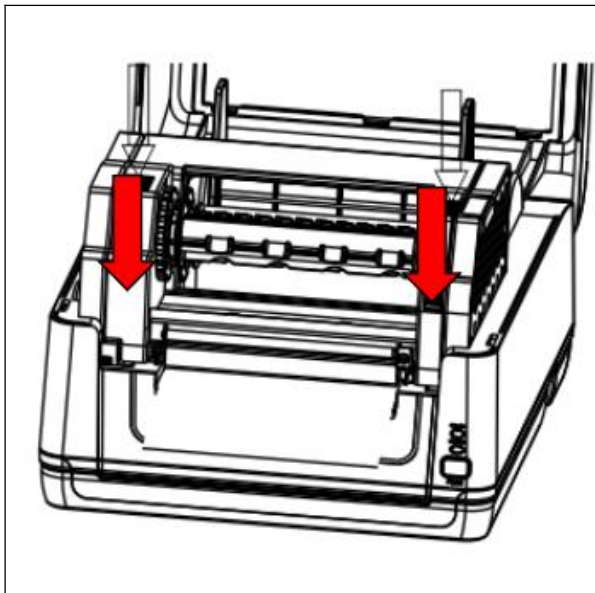

6、 Press both hands down at the arrow in the left figure to close the print head. Please make sure that the print head is completely closed to ensure the print quality;

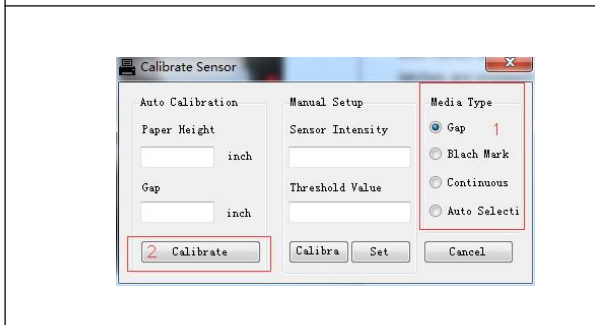

7、 Please use the "Chainway Diagnostic Tool " to set appropriate sensor type according to the paper type and calibrate the label sensor (open the "Chainway Diagnostic Tool" and select the "printer setting" page press the "sensor calibration" key), see Chapter 5.3,

Note:the label sensor of this series of models is movable. Please confirm that the gap (or black label) of the paper has a pass through sensor .

Media loading path

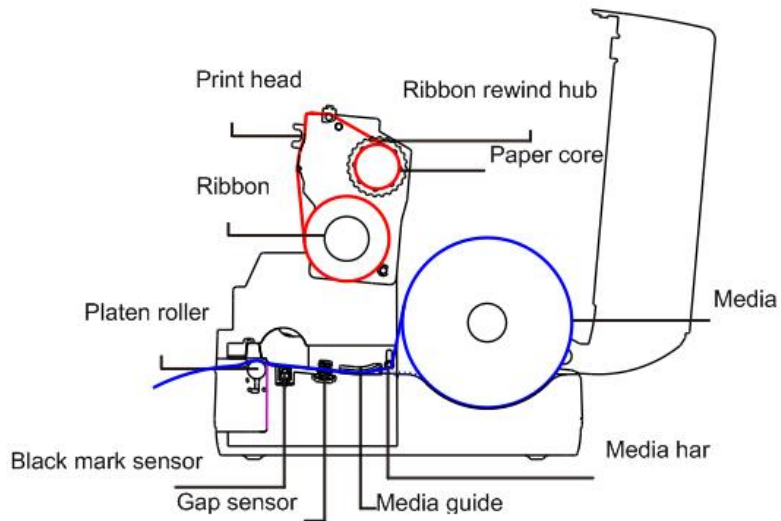

3.3.2 Loading the Media in Peel-off mode (Option)

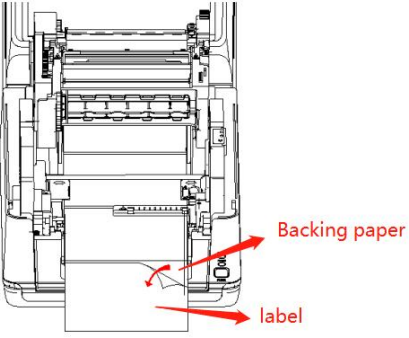
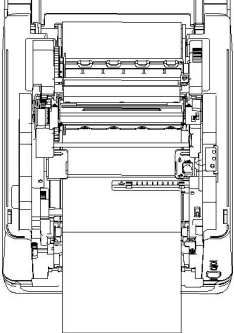
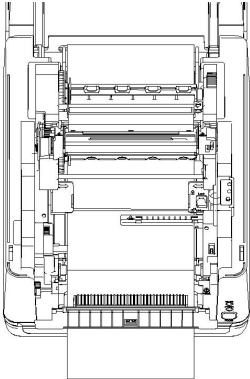
	<p>1、 Please refer to chapter 3.3.1. After installing the label paper, use the "Chainway Diagnostic Tool " to set the appropriate sensor type according to the paper type and calibrate the label sensor;</p>
	<p>2、 First pull the front end of the label to the paper outlet for a section, and then remove the label paper, leaving only the bottom paper;</p>
	<p>3、 Open the stripper panel and pass the bottom paper through the bottom paper outlet;</p>

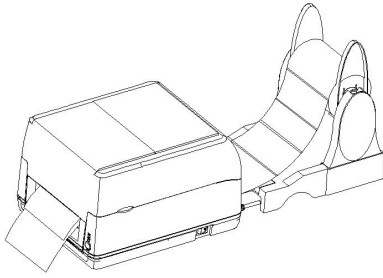

4、 Close the stripper panel. Use the "Chainway Diagnostic Tool" to select the post printing action as "paper stripping mode" and press the "setting key" to set the printer to paper stripping mode

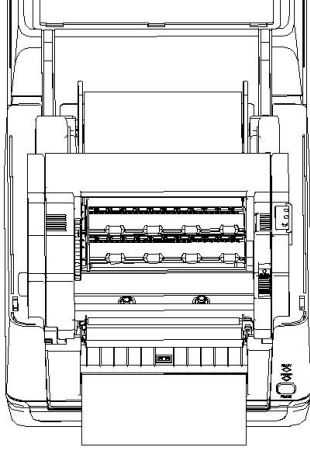

5、 Turn off print head, and the automatic paper stripping mode paper loading has been set;

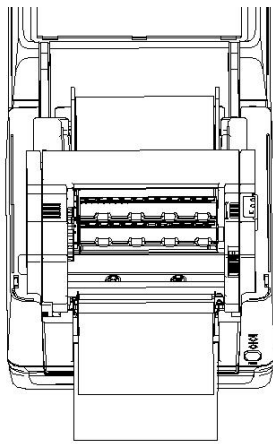

6、 Please press paper feed key to test and confirm;

Note:

Please calibrate the gap/black mark sensor when changing media.

3.3.3 Loading the Media in Cutter Mode (Option)

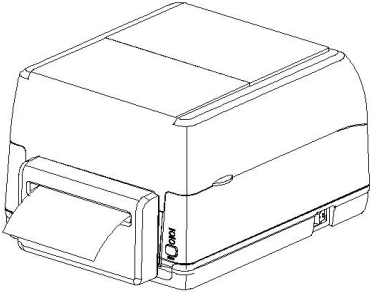
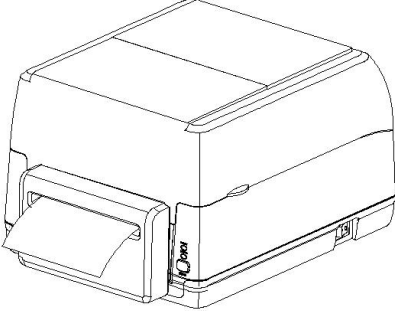
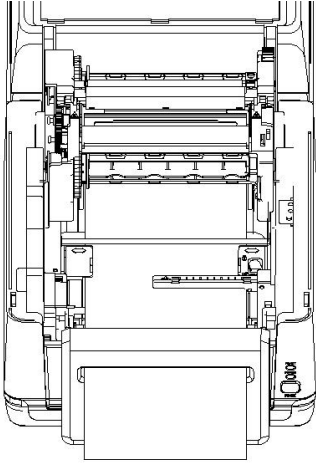
	<p>1、 Please refer to chapter 3.3.1 to install label paper;</p>
	<p>2、 Put front end of the label through paper outlet of the cutter;</p>
	<p>Close print head and upper cover of the printer. Use "Chainway diagnostic tool" to select post print action as "cutter mode" and press the "set" key to set the printer to cutter mode. Please press the paper feed key to test and confirm;</p>

Note:

Please calibrate the gap/black mark sensor when changing media.

3.3.4 External Label Roll Mount Installation (Option)

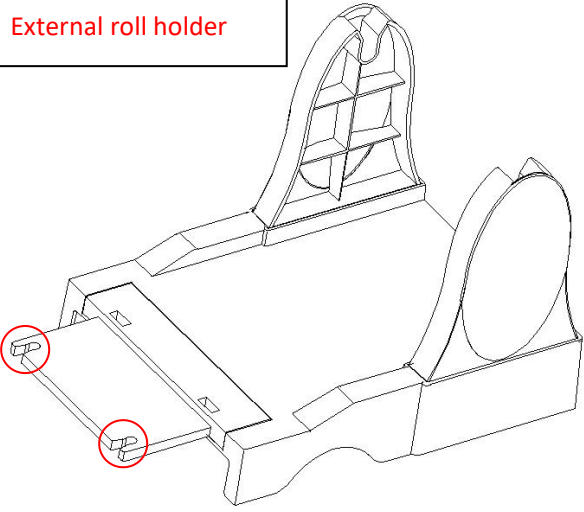
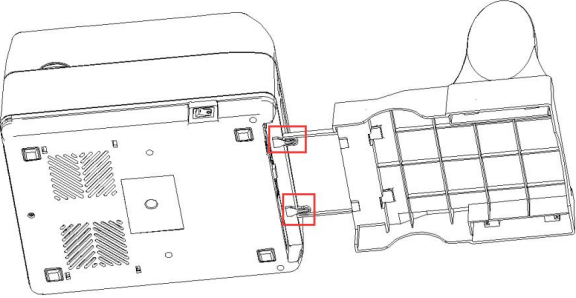
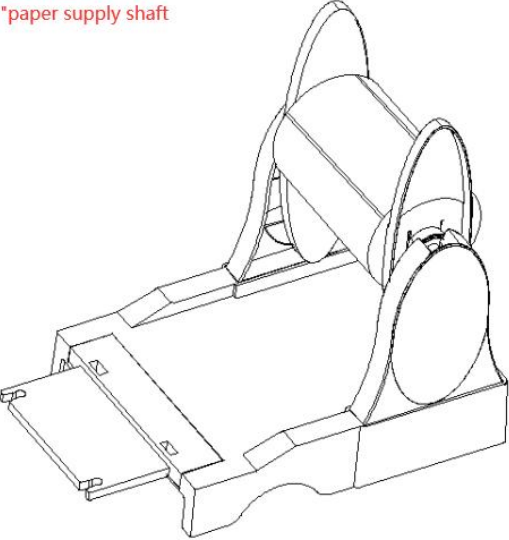
<p>External roll holder</p> 	<p>1、 As shown in the left figure, clamp the extension board to external roll holder;</p>
	<p>2、 Fix external label holder on the bottom of the printer through the extension plate (if you only buy the external paper roll holder, please place it directly behind the machine);</p>
<p>1 *paper supply shaft</p> 	<p>3、 Install 3 "(or 1") paper supply shaft behind the label roll and place it on the external roll holder;</p>

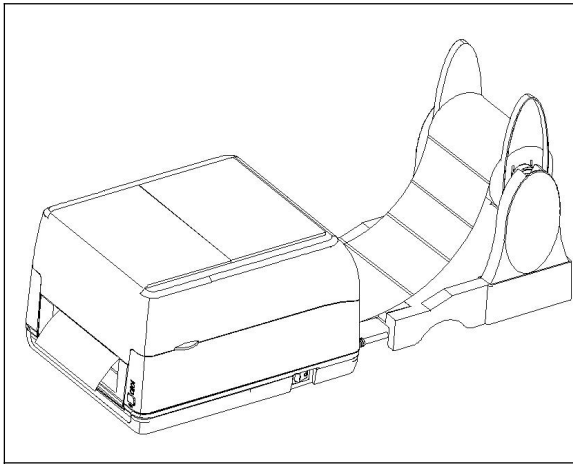

4、 Feed the paper into the machine through the external paper inlet at the rear of the machine;

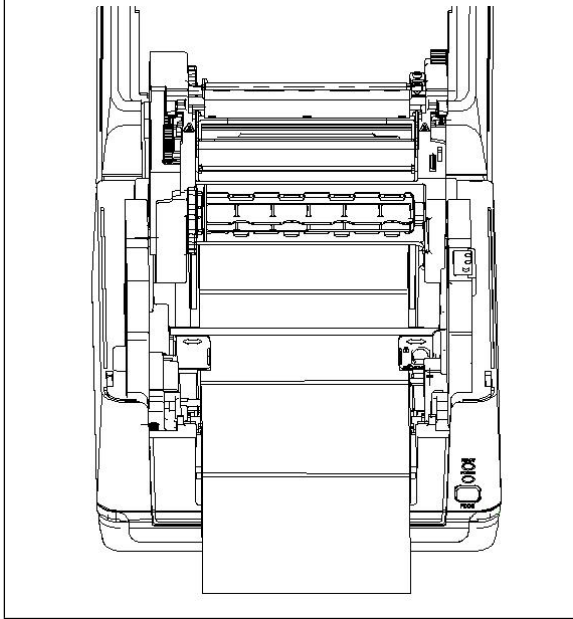

5、 Please refer to chapter 3.3.1 to install label paper and use "Chainway diagnostic tool" to calibrate the paper sensor;

Note:
Please calibrate the gap/black mark sensor when changing media.

4. LED and Button Functions

This printer has a button and red and blue indicator lights. By indicating the LED with different color and pressing the button, printer can feed labels, pause the printing job, select and calibrate the media sensor, print printer self-test report, reset printer to defaults (initialization). Please refer to the button operation below for different functions.

4.1 LED Indicator

LED Color	Description
Blue/ Solid	This illuminates that power on, printer standby to print, printer clearing data.
Blue / Flash	This illuminates that the system is downloading data from PC to memory or the printer is paused.
Red / Solid	This illuminates printer head open, cutter error.
Red / Flash	This illuminates a printing error, such as head open, paper empty, paper jam, ribbon empty, or memory error etc.

4.2 Regular Button Functions

1. Feed labels

When the printer is at ready states (Blue/ Solid), press the button to feed one label to the beginning of next.

2. Pause the printing job

When the printer is at printing states, press the button to pause a print job. When the printer is paused the LED will be blue blinking. Press the button again to continue the printing job.

4.3 Power-on Utilities

There are six power-on utilities to set up and test printer hardware. These utilities are activated by pressing FEED button then turning on the printer power simultaneously and release the button at different color of LED.

Please follow the steps below for different power-on utilities.

1. Turn off the printer power switch.
2. Hold on the button then turn on the power switch.
3. Release the button when LED indicates with different color for different functions.

<i>Power on utilities</i>	The LED color will be changed as following pattern:						
LED color Functions	Red /blue	Blue-turn off Red-flash	Blue-flash Red-flash	Blue-flash Red-turn off	Blue-turn on Red-flash	Blue-flash Red-turn on	Solid blue
		(5 blinks)	(5 blinks)	(5 blinks)	(5 blinks)	(5 blinks)	
1. Ribbon sensor calibration and gap /black mark sensor calibration		<i>Release</i>					
2. Gap / black mark sensor calibration, Self-test and enter dump mode			<i>Release</i>				
3. Printer initialization				<i>Release</i>			
3. Set black mark sensor as media sensor and calibrate the black mark sensor					<i>Release</i>		
4. Set gap sensor as media sensor and calibrate the gap sensor						<i>Release</i>	
6. Skip AUTO.BAS							<i>Release</i>

4.3.1 Printer self check and paper learning function

When the printer is in standby trouble free state,

- (1) Press and hold paper feeding button for 3s, BEEP and blue light flashes once, and then the self check page is printed,
- (2) Press and hold the paper feeding button for 5s, BEEP and blue light flashes twice to calibrate the paper;

4.3.2 Ribbon and Gap/Black Mark Sensor Calibration

Gap/black mark sensor sensitivity should be calibrated at the following conditions:

1. A brand new printer
2. Change label stock
3. Printer initialization

Please follow the steps below to calibrate the ribbon and gap/black mark sensor.

1. Please confirm that the carbon tape and label paper are properly installed (under the condition of using heat transfer printing)
2. Turn off the power switch.
3. Hold on the button then turn on the power switch.
4. Release the button when LED becomes red and blinking, blue LED is turn off.

■ The LED color will be changed as following order

Red&blue turn on blue blue turn off & red (flashing 5 times) blue & red at the same time (flashing 5 times) red turn off & blue (flashing 5 times) blue turn on & red flashing (flashing 5 times) red turn on & blue flashing 5 times blue (fixed)

Note:

Please select gap or black mark sensor by sending **GAP** or **BLINE** command to printer prior to calibrate the sensor.

For more information about **GAP** and **BLINE** command, please refer to Chainway programming manual.

4.3.3 Gap/Black Mark Calibration, Self-test and Dump Mode

While calibrate the gap/black mark sensor, printer will measure the label length, print the internal configuration (self-test) on label and then enter the dump mode. To calibrate gap or black mark sensor, depends on the sensor setting in the last print job.

Please follow the steps below to calibrate the sensor.

1. Please confirm that the label paper is properly installed,
2. Turn off the power switch.
3. Hold on the button then turn on the power switch.
4. Release the button when blue & red LED becomes blinking at the same time.

- The LED color will be changed as following order

Red&blue turn on blue blue turn off & red (flashing 5 times) blue & red at the same time (flashing 5 times) red turn off & blue (flashing 5 times) blue turn on & red flashing (flashing 5 times) red turn on & blue flashing 5 times blue (fixed)

5. It calibrates the sensor and measures the label length and prints internal settings then enter the dump mode.
6. Please turn the printer back on and off again to return to the normal printing mode;

Note:

Please select gap or black mark sensor by **Diagnostic Tool** or by **GAP** or **BLINE** command prior to calibrate the sensor. For more information about **GAP** and **BLINE** command, please refer to Chainway programming manual.

Self-test

Printer will print the printer configuration after gap/black mark sensor calibration. Self-test printout can be used to check if there is any dot damage on the heater element, printer configurations and available memory space.

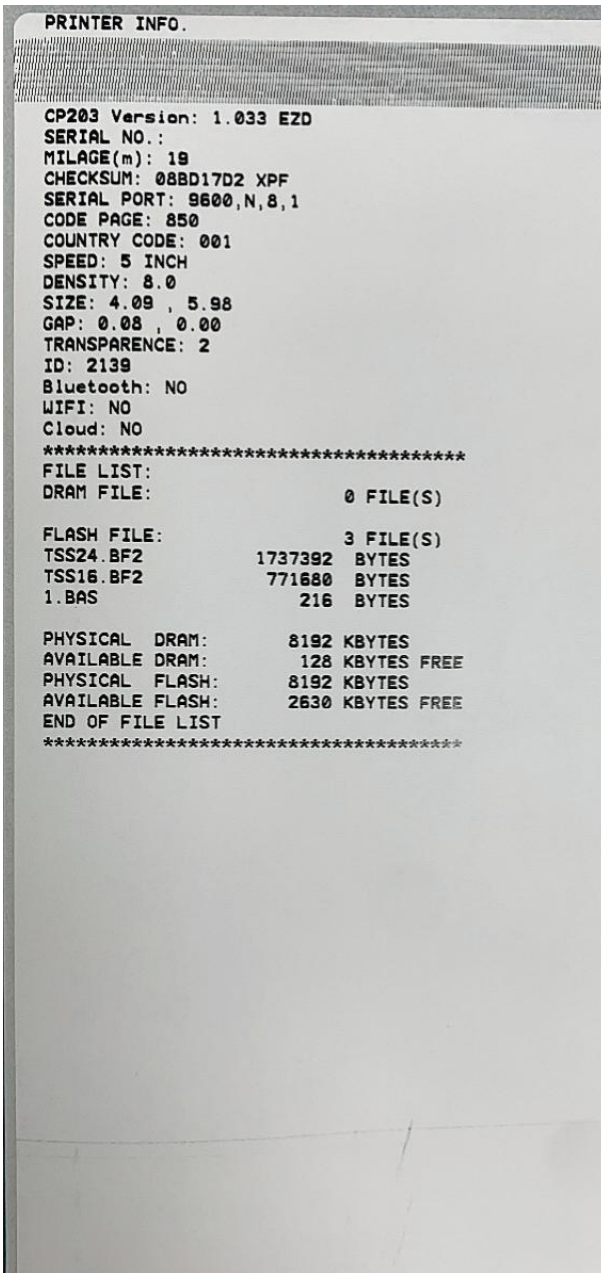
 <pre> PRINTER INFO. CP203 Version: 1.033 E2D SERIAL NO.: MILAGE(m): 19 CHECKSUM: 08BD17D2 XPF SERIAL PORT: 9600,N,8,1 CODE PAGE: 850 COUNTRY CODE: 001 SPEED: 5 INCH DENSITY: 8.0 SIZE: 4.09 , 5.98 GAP: 0.08 , 0.00 TRANSPARENCE: 2 ID: 2139 Bluetooth: NO WIFI: NO Cloud: NO ***** FILE LIST: DRAM FILE: 0 FILE(S) FLASH FILE: 3 FILE(S) TSS24.BF2 1737392 BYTES TSS16.BF2 771680 BYTES 1.BAS 216 BYTES PHYSICAL DRAM: 8192 KBYTES AVAILABLE DRAM: 128 KBYTES FREE PHYSICAL FLASH: 8192 KBYTES AVAILABLE FLASH: 2630 KBYTES FREE END OF FILE LIST ***** </pre>	<p>Printer self test page:</p> <ul style="list-style-type: none"> Model & firmware version Machine serial number Mileage of print head Check code Serial port setting character set Country code Printing speed Print density Paper size (width, height) Black mark or gap dimension (vertical gap, offset) Sensor strength
---	---

■ Dump mode

Printer will enter dump mode after printing printer configuration. In the dump mode, all characters will be printed in 2 columns as following. The left side characters are received from your system and right side data are the corresponding hexadecimal value of the characters. It allows users or engineers to verify and debug the program.

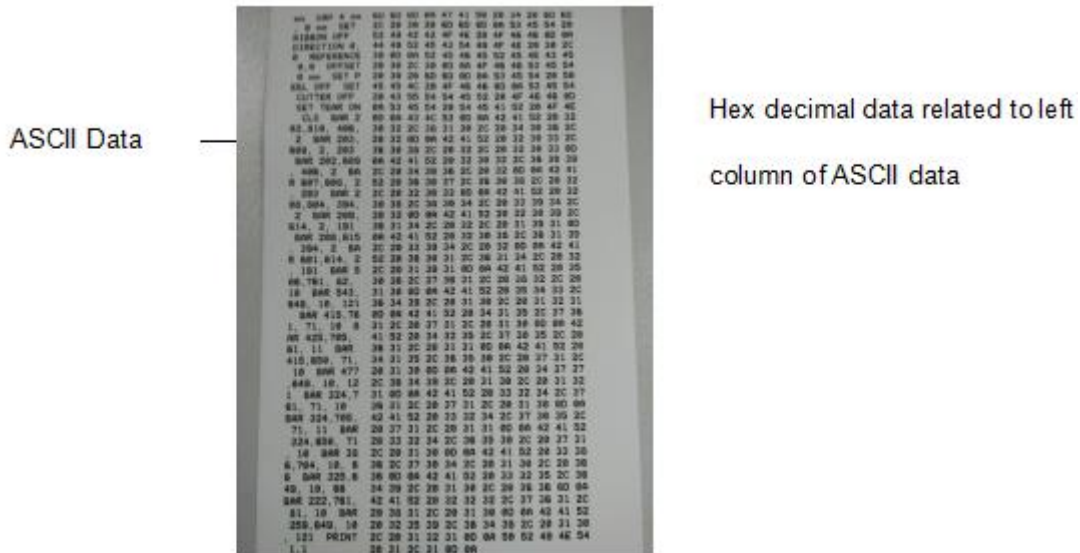

Note:

1. Dump mode requires 4" wide paper width.
2. Turn off / on the power to resume printer for normal printing.

4.3.4 Printer Initialization

Printer initialization is used to clear DRAM and restore printer settings to defaults. The only one exception is ribbon sensitivity, which will not be restored to default.

Printer initialization is activated by the following procedures.

1. Turn off the power switch.
2. Hold on the button then turn on the power switch.
3. Release the button when LED red flashing & blue turn off.

- The LED color will be changed as following:

Red & blue turn on blue blue turn off & red (flashing 5 times) blue & red at the same time (flashing 5 times) red turn off & blue (flashing 5 times) blue turn on & red flashing (flashing 5 times) red turn on & blue flashing 5 times blue (fixed)

Parameter	Default setting
Speed	152 mm/sec (6 ips) (203DPI) 127 mm/sec (5 ips) (300DPI)
Density	8
Label Width	4" (101.5 mm)
Label Height	2.5" (63.5 mm)
Sensor Type	Gap sensor
Gap Setting	0.078"(2.0 mm)
Print Direction	0
Reference Point	0,0 (upper left corner)
Offset	0
Tear Mode	On
Peel off Mode	Off
Cutter Mode	Off
Serial Port Settings	9600 bps, none parity, 8 data bits, 1 stop bit
Code Page	850
Country Code	001
Clear Flash Memory	No
IP Address	DHCP

Printer configuration will be restored to defaults as below after initialization.

4.3.5 Set Black Mark Sensor as Media Sensor and Calibrate the Black Mark Sensor

Please follow the steps as below.

1. Turn off the power switch.
2. Hold on the button then turn on the power switch.
3. Release the button when LED turns blue turn on & red after 5 blue blinks.

■ The LED color will be changed as following:

Red&blue turn on blue blue turn off &red (flashing 5 times) blue &red at the same time (flashing 5 times) red turn off & blue (flashing 5 times) blue turn on&red flashing (flashing 5 times) red turn on & blue flashing 5 times blue (fixed)

4. At this time, printer will make black line mark sensor calibration, and finally the power indicator is in blue ready state

4.3.6 Set Gap Sensor as Media Sensor and Calibrate the Gap Sensor

Please follow the steps as below.

1. Turn off the power switch.
2. Hold on the button then turn on the power switch.
3. Release the button when LED turns red turn on & blue blink after 5 times.

■ The LED color will be changed as following:

Red&blue turn on blue blue turn off &red (flashing 5 times) blue &red at the same time (flashing 5 times) red turn off & blue (flashing 5 times) blue turn on&red flashing (flashing 5 times) red turn on & blue flashing 5 times blue (fixed)

4.3.7 Skip AUTO.BAS

Chainway programming language allows user to download an auto execution file to flash memory. Printer will run the AUTO.BAS program immediately when turning on printer power. The AUTO.BAS program can be interrupted without running the program by the power-on utility.

Please follow the procedures below to skip an AUTO.BAS program.

1. Turn off printer power.
2. Press the FEED button and then turn on power.
3. Release the FEED button when LED becomes solid blue.
4. Printer will be interrupted to run the AUTO.BAS program.

■ The LED color will be changed as following:

Red&blue turn on blue blue turn off &red (flashing 5 times) blue &red at the same time (flashing 5 times) red turn off & blue (flashing 5 times) blue turn on&red flashing (flashing 5 times) red turn on & blue flashing 5 times blue (fixed)

5. Chainway Diagnostic Tool

Chainway Diagnostic Utility is an integrated tool incorporating features that enable you to explore a printer's settings/status; change a printer's settings; download graphics, fonts and firmware; create a printer bitmap font; and send additional commands to a printer. With the aid of this powerful tool, you can review printer status and settings in an instant, which makes it much easier to troubleshoot problems and other issues.

5.1 Start Chainway Diagnostic Tool

1. Double click on Chainway Diagnostic tool icon  Chainway Diagnostic Tool.exe to start software;
2. There are four features (Printer Configuration, File Manager, Bitmap Font Manager, Command Tool) included in the Diagnostic utility.

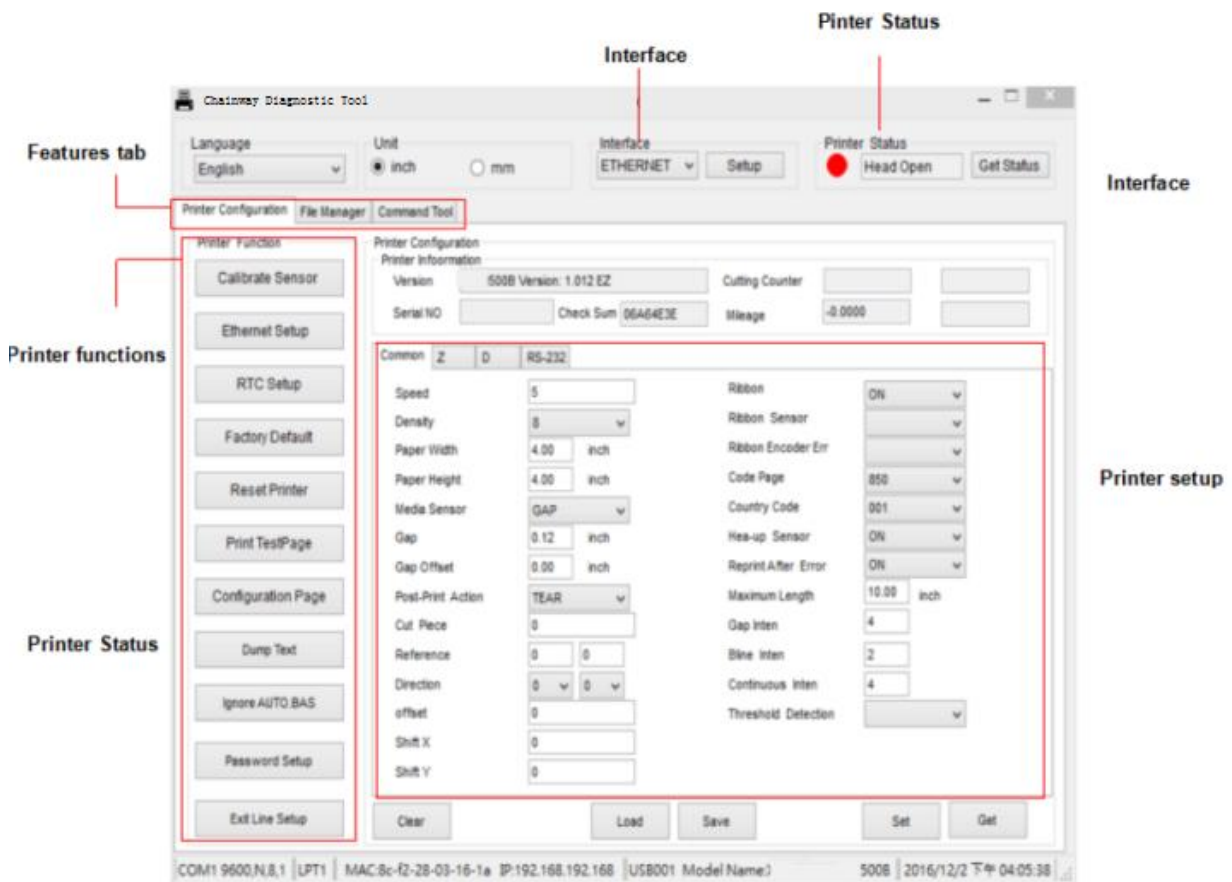

5.2 Printer Function

1. Select the PC interface connected with barcode printer.

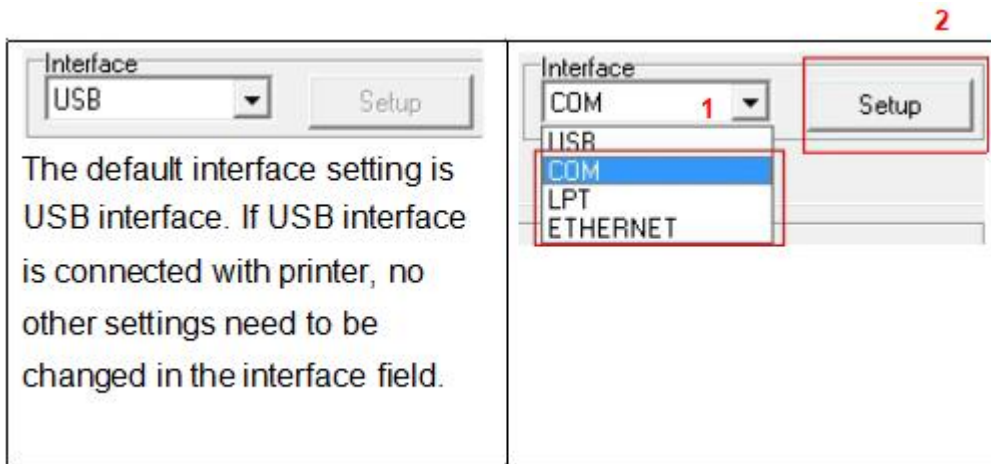

2. Click the “Printer Function” button to setup.
3. The detail functions in the Printer Function Group are listed as below.

Printer Function	Function	Description
Calibrate Sensor	Calibrate Sensor	Calibrate the sensor specified in the Printer Setup group media sensor field
Ethernet Setup	Ethernet Setup	Setup the IP address, subnet mask, gateway for the on board Ethernet
RTC Setup	RTC Setup	Synchronize printer Real Time Clock with PC
Factory Default	Print Test Page	Print a test page
Reset Printer	Reset Printer	Reboot printer
Print TestPage	Factory Default	Initialize the printer and restore the settings to factory default. (Please refer section 4.3.3)
Configuration Page	Dump Text	To activate the printer dump mode.
Dump Text	Ignore AUTO.BAS	Ignore the downloaded AUTO.BAS program
Ignore AUTO.BAS	Configuration Page	Print printer configuration (Please refer section 4.3.2)
Password Setup	Password Setup	Set the password to protect the settings
Exit Line Setup		

5.3 Calibrating Media Sensor by Chainway Diagnostic Tool

5.3.1 Auto Calibration

1. Make sure the media is install ready and print head mechanism is closed. (Please refer to section 3.3.)

Note: The media sensor position is moveable. Please make sure the gap (↕) or black mark is at the location where media gap/black mark will pass through for Sensing.

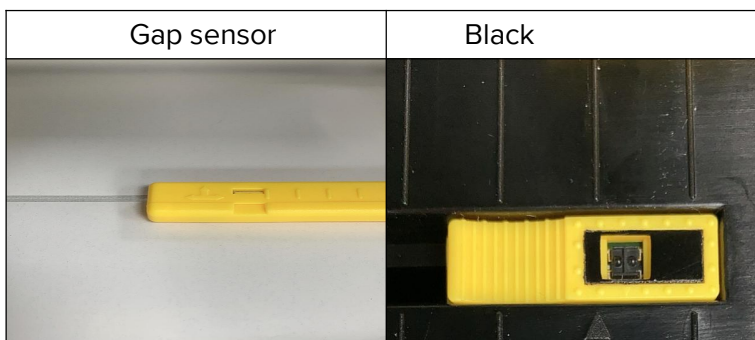

2. Turn on the printer power switch.
3. Open Diagnostic tool and set interface. (The default setting is USB.)



The default interface setting is USB interface. If USB interface is connected with printer, no other settings need to be changed in the interface field.

4. Click the “Calibrate Sensor” button.
5. Select the media type and click the “Calibrate” button.

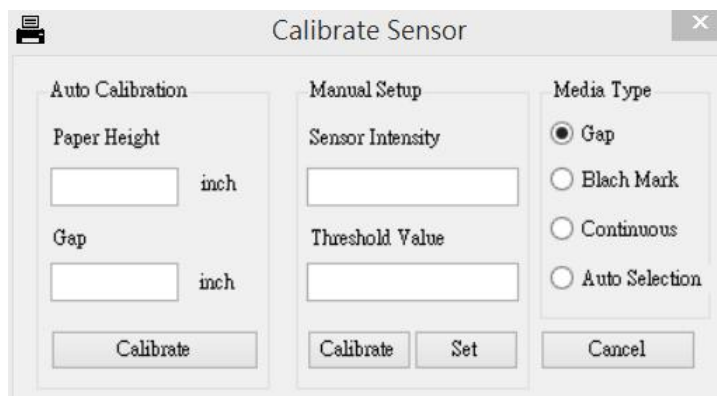

5.4 Setting Ethernet by Diagnostic Utility (Option)

The Chainway Diagnostic Utility is enclosed in the CD disk \Utilities directory.

Users can use Diagnostic Tool to setup the Ethernet by RS-232, USB and Ethernet interfaces.

The following contents will instruct

users how to configure the Ethernet by these three interfaces.

5.4.1 Using USB interface to setup Ethernet interface

1. Connect the USB cable between the computer and the printer.
2. Turn on the printer power.
3. Start the Diagnostic Utility by double clicking on the  Chainway Diagnostic Tool.exe icon.
4. The Diagnostic Utility default interface setting is USB interface. If USB interface is connected with printer, no other settings need to be changed in the interface field.

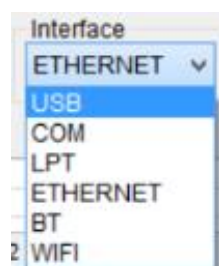

5. Click on the “Ethernet Setup” button from “Printer Function” group in Printer Configuration tab to setup the IP address, subnet mask and gateway for the on board Ethernet.

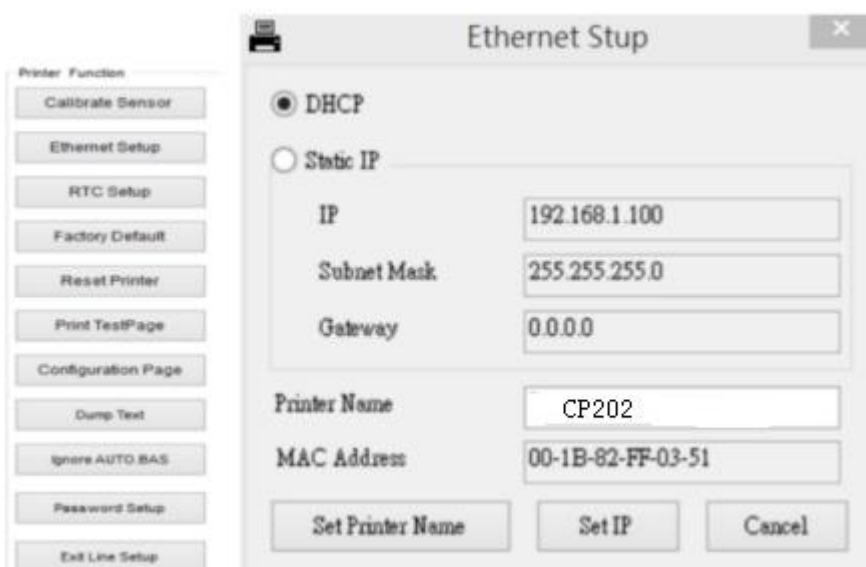

5.4.2 Using RS-232 interface to setup Ethernet interface

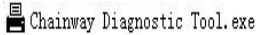
1. Connect the computer and the printer with a RS-232 cable.
2. Turn on the printer power.
3. Start the Diagnostic Utility by double clicks on the  icon.
4. Select “COM” as interface then click on the “Setup” button to setup the serial port baud rate, parity check, data bits, stop bit and flow control parameters.

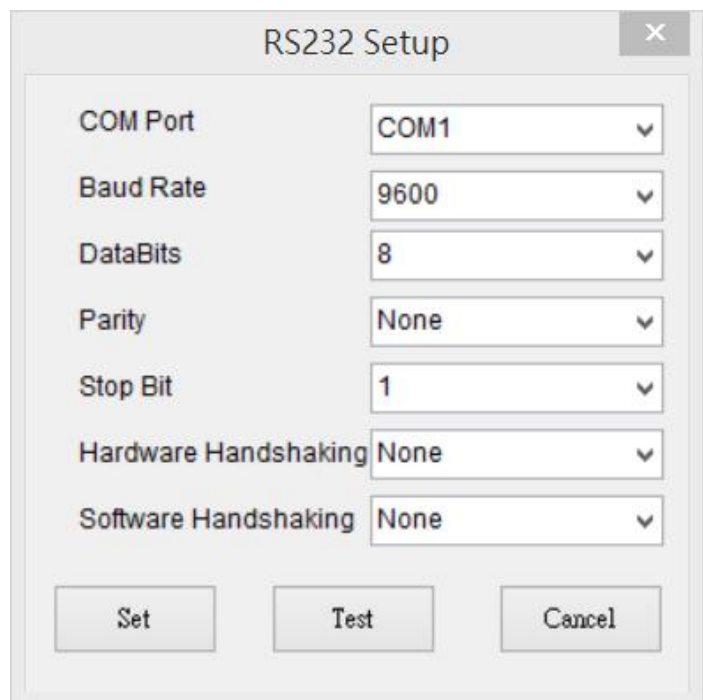
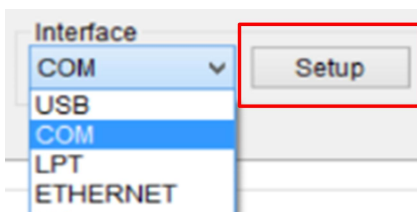

5. Click on the “Ethernet Setup” button from printer function of Printer Configuration tab to setup the IP address, subnet mask and the gateway for the on board Ethernet.

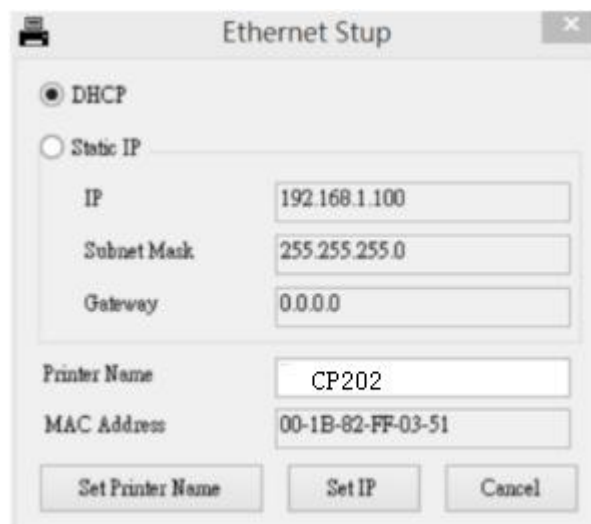
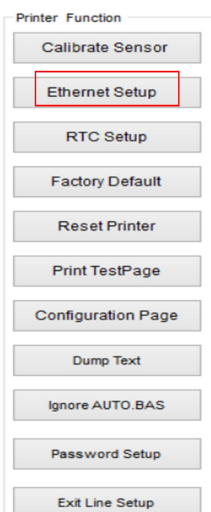

5.4.3 Using Ethernet interface to setup Ethernet interface

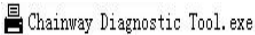
1. Connect the computer and the printer to the LAN.
2. Turn on the printer power.
3. Start the Diagnostic Utility by double clicks on the  icon.
4. Select “Ethernet” as the interface then click on the “Setup” button to setup the IP address, subnet mask and gateway for the on board Ethernet.

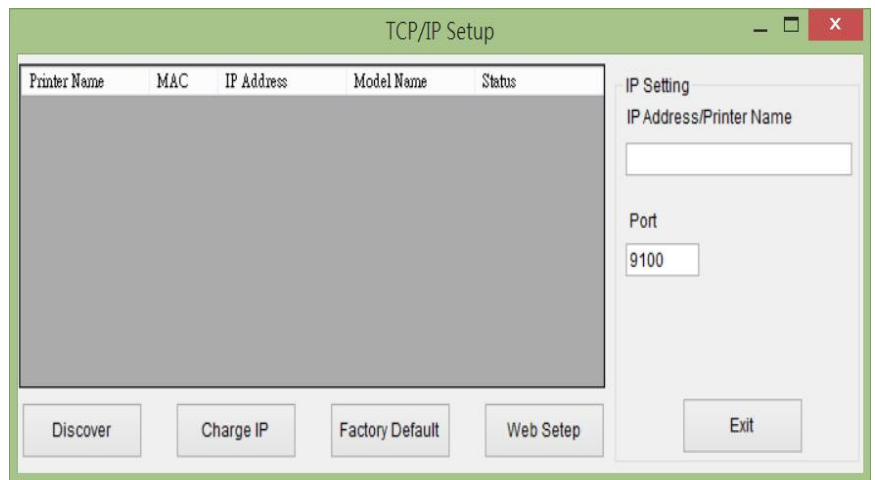
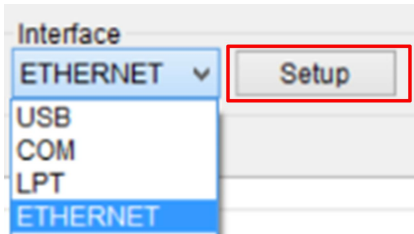

5. Click the “Discover Device” button to explore the printers that exist on the network.
6. Select the printer in the left side of listed printers, the correspondent IP address will be shown in the right side “IP address/Printer Name” field.
7. Click “Change IP Address” to configure the IP address obtained by DHCP or static.

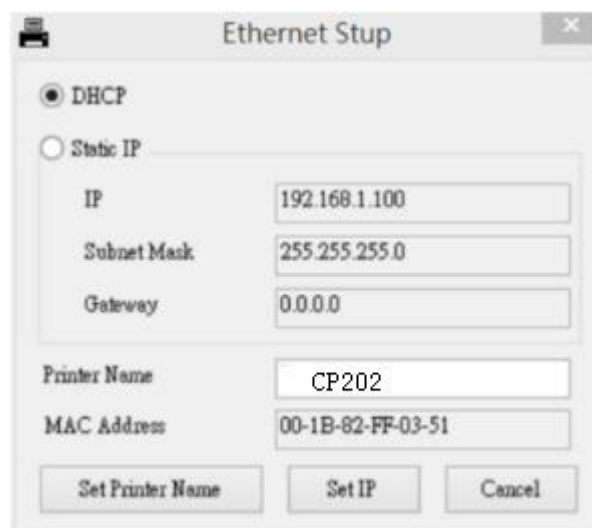

The default IP address is obtained by DHCP. To change the setting to static IP address, click “Static IP” radio button then enter the IP address, subnet mask and gateway. Click “Set IP” to take effect the settings.

Users can also change the “Printer Name” by another model name in this fields then click “Set Printer Name” to take effect this change.

Note: After clicking the “Set Printer Name” or “Set IP” button, printer will reset to take effect the settings.

8. Click “Exit” button to exit the Ethernet interface setup and go back to Diagnostic Tool main screen.

Factory Default button

This function will reset the IP, subnet mask, gateway parameters obtained by DHCP and reset the printer name.

Web setup button

Except to use the Diagnostic Utility to setup the printer, you can also explore and configure the printer settings and status or update the firmware with the IE or Firefox web browser. This feature provides a user friendly setup interface and the capability to manage the printer remotely over a network.

6. Troubleshooting

6.1 Common Problems

The following guide lists the most common problems that may be encountered when operating this barcode printer. If the printer still does not function after all suggested solutions have been invoked, please contact the Customer Service Department of your purchased reseller or distributor for assistance.

Problem	Possible Cause	Recovery Procedure
Power indicator does not illuminate	* The power cord is not properly connected.	* Plug the power cord in printer and outlet. * Switch the printer on.
- The printer status from Chainway Diagnostic Tool shows "Head Open" .	* The printer carriage is open.	* Please close the print carriage.
- The printer status from Chainway Diagnostic Tool shows "Ribbon End Err." Or "Ribbon Encoder Err."	* Running out of ribbon. * The ribbon is installed incorrectly.	* Supply a new ribbon roll. * Please refer to the steps on section 3.2 to re-install the ribbon.
- The printer status from Chainway Diagnostic Tool shows "Out of Paper" .	* Running out of label. * The label is installed incorrectly. * Gap/black mark sensor is not calibrated.	* Supply a new label roll. * Please refer to the steps on section 3.3 to reinstall the label roll. * Calibrate the gap/black mark sensor.
- The printer status from Chainway Diagnostic Tool shows "Paper Jam" .	* Gap/black mark sensor is not set properly. * Make sure label size is set properly. * Labels may be stuck inside the printer mechanism.	* Calibrate the gap/black mark sensor. * Set label size correctly.

<p>Not Printing</p>	<p>* Cable is not well connected to serial or USB interface or parallel port. * The serial port cable pin configuration is not pin to pin connected.</p>	<p>* Re-connect cable to interface. * If using serial cable, - Please replace the cable with pin to pin connected. - Check the baud rate setting. The default baud rate setting of printer is 9600,n,8,1. * If using the Ethernet cable, - Check if the Ethernet RJ-45 connector blue LED is lit on. - Check if the Ethernet RJ-45 connector amber LED is blinking. - Check if the printer gets the IP address when using DHCP mode. - Check if the IP address is correct when using the static IP address. - Wait a few seconds let the printer get the communication with the server then check the IP address setting again. * Change a new cable. * Ribbon and media are not compatible. * Verify the ribbon-inked side. * Reload the ribbon again. * Clean the print head. * The print density setting is incorrect. * Print head's harness connector is not well connected with printhead. Turn off the printer and plug the connector again. * Check your program if there is a command PRINT at the end of the file and there must have CRLF at the end of each command line.</p>
<p>Memory full (FLASH / DRAM)</p>	<p>* The space of FLASH/DRAM is full.</p>	<p>* Delete unused files in the FLASH/DRAM. * The max. numbers of DRAM is 256 files. * The max. user addressable memory space of DRAM is 256KB. * The max. numbers of file of FLASH is 256 files. * The max. user addressable memory space of FLASH is 2560KB.</p>
<p>microSD card is unable to use</p>	<p>* microSD card is damaged. * microSD card doesn't insert correctly. * Use the non-approved microSD card manufacturer.</p>	<p>* Use the supported capacity microSD card. * Insert the microSD card again. * The supported microSD card spec and the approved microSD card manufacturers, please refer to section 2.2.3.</p>

<p>Poor Print Quality</p>	<ul style="list-style-type: none"> * Ribbon and media is loaded incorrectly * Dust or adhesive accumulation on the print head. * Print density is not set properly. * Printhead element is damaged. * Ribbon and media are incompatible. * The printhead pressure is not set properly. 	<ul style="list-style-type: none"> * Reload the supply. * Clean the print head. * Clean the platen roller. * Adjust the print density and print speed. * Run printer self-test and check the print head test pattern if there is dot missing in the pattern. * Change proper ribbon or proper label media. * The print head mechanism does not latch the print head properly.
<p>Cutter is not working</p>	<ul style="list-style-type: none"> * The connector is loose. * Cutter jam. * Cutter PCB is damaged. 	<ul style="list-style-type: none"> * Plug in the connect cable correctly. * Remove the label. * Make sure the thickness of label is less than 0.19 mm. * Replace a cutter driver IC board.

7. Maintenance

This session presents the clean tools and methods to maintain your printer.

1. Please use one of following material to clean the printer.

- Cotton swab
- Lint-free cloth
- Vacuum / Blower brush
- Medical alcohol

2. The cleaning process is described as following,

Printer Part	Method	Interval
Print Head	1. Always turn off the printer before cleaning the print head. 2. Allow the print head to cool for a minimum of one minute. 3. Use a cotton swab and Medical alcohol to clean the print head surface.	Clean the print head when changing a new label roll
Platen Roller	1. Turn the power off. 2. Rotate the platen roller and wipe it thoroughly with Medical alcohol and a cotton swab, or lint-free cloth.	Clean the platen roller when changing a new label roll
Tear Bar/Peel Bar	Use the lint-free cloth with Medical alcohol to wipe it.	As needed
Sensor	Compressed air or vacuum	Monthly
Exterior	Wipe it with water-dampened cloth	As needed
Interior	Brush or vacuum	As needed

Note:

Do not touch the printer head directly with your hands. If you touched accidentally, please clean it with a cotton swab dipped medical alcohol.

Please use medical alcohol. Do not use industrial alcohol which will damage the printer head.

If you frequently get error messages from the printer, please often clean your printer's sensor
 Equipment for safe use in tropical climate conditions

This is a Class A product. In the living environment, this product may cause radio interference.

In this case, users may need to take practical measures to the interference

Update record

Date	Content	Editor
2022/11/03	Release V1.0	Fangjiading